

Knife gate valves SLH and SLX

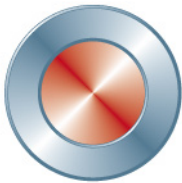
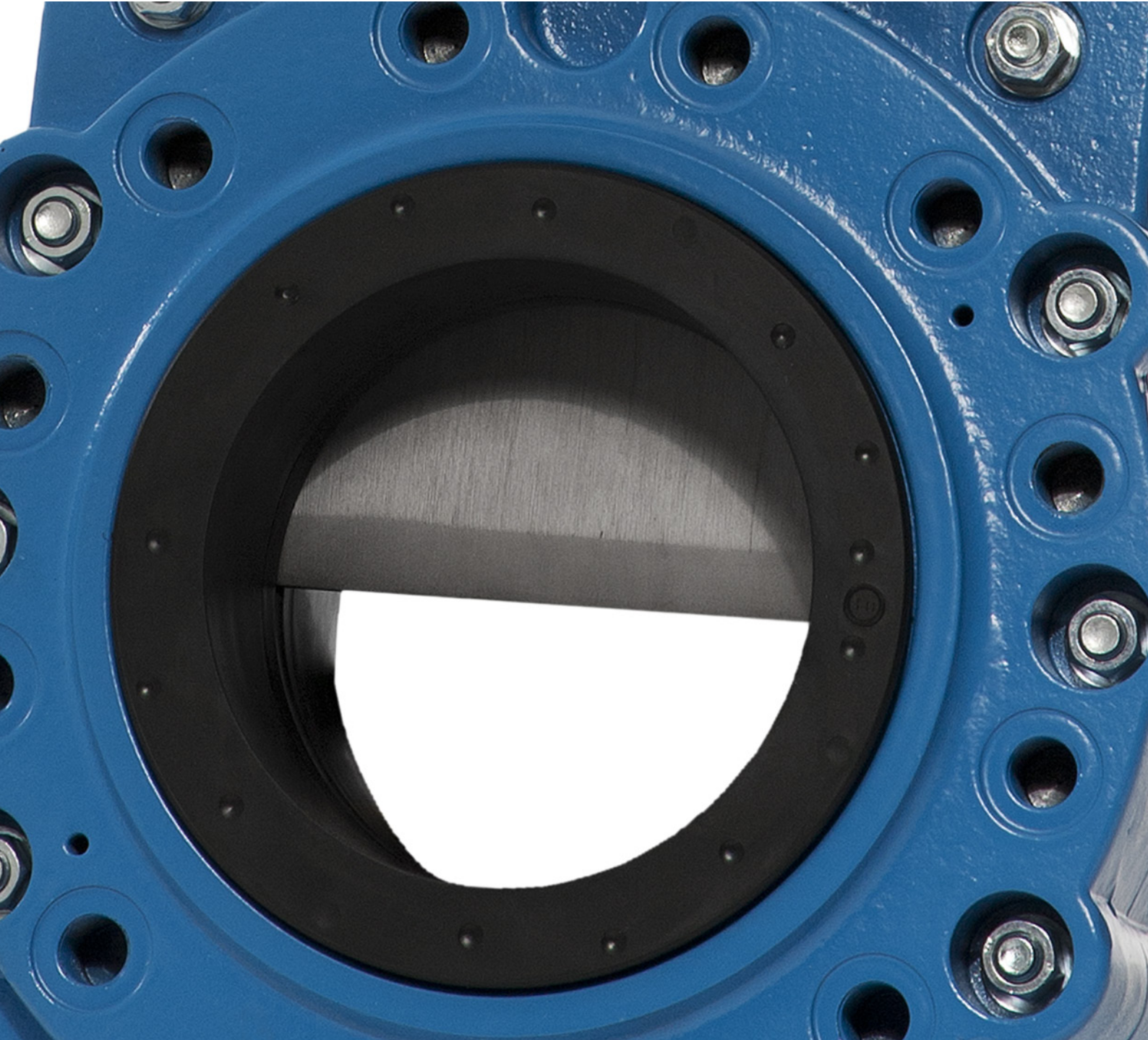

Stafsjö
SINCE 1666

avrorra-arm.ru
+7 (495) 956-62-18

Data is only for informational purpose. All specifications are subject to change without notice.

Knife gate valves SLH and SLX

Stafsjö's knife gate valves SLH and SLX are designed for the most demanding high pressure applications with slurry and other abrasive media where operation reliability and low life cycle cost are emphasized. The SLH is designed for pressure up to 20 bar/290 psi while the SLX is designed for 50 bar/720 psi.

When these valves are in opened position, the seats form a tight extension of the pipe line and no metal parts are in contact with the media. When the valve closes the seats are displaced axially forming a seal with the gate until it forms a complete closure – 100% tight in any pressure direction.

The SLH and SLX have fully lugged coated valve bodies in nodular iron with integrated purge ports to utilize if the bottom screw plugs are assembled on the valves. The unique seats are available in low friction special EPDM or natural rubber. These seal against a gate in high strength stainless steel specially machined, grinded and coated to reduce the friction when the valve is operated. The gland box system is as standard supplied with three layers of our TwinPack™ and box bottom scrapers in order to give a first-rate sealing and a straight gate guidance.

The top works is modular designed and there are several actuator types and accessories to choose from in our standard collection – all easily exchangeable between each other. For security reason the valve is always supplied ready to be locked in either opened or closed position.

The SLH/SLX valve is designed, manufactured, inspected and tested according to the European Pressure Equipment Directive (PED 97/ 23/EC) category I and II module A1. The valve is CE marked when it is applicable.

Other slurry valves are the lugged SLV available up to DN 900 and the flanged SLF.

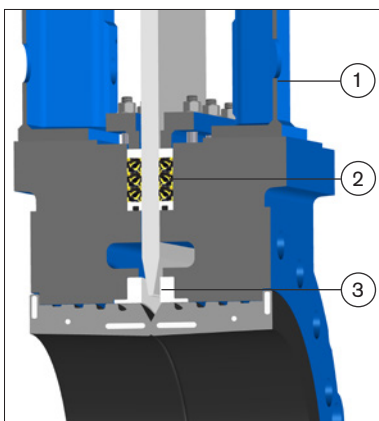

A precise gate guidance extend the service life

A solid top works (1), a robust gland box system (2), internal guiding supports (3) guarantee a precise gate guidance, which is crucial during cycling to minimize the wear on the seats.

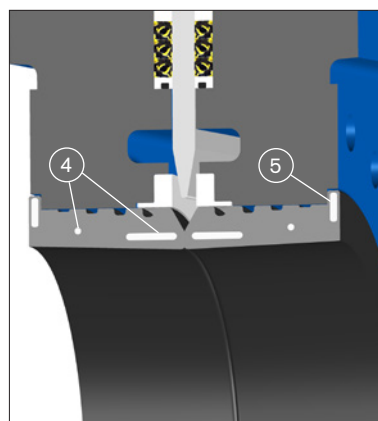

Built in steel reinforcements improve the performance

The front reinforcement rings (4) ensure the seats shape, position and strength remain during operation while the flange sealing reinforcements (5) secure a tight and exact position of the seats towards the gate and connecting flanges.

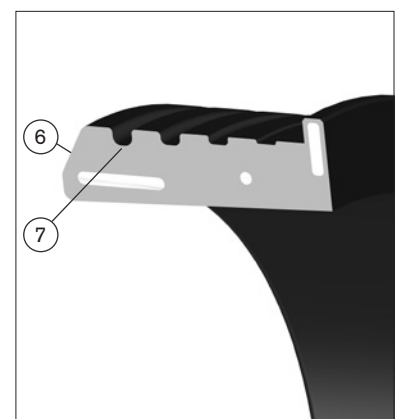

Integrated expansion areas give low operating force and minimize the stress on the seats

The seat entrance area (6) is designed to give a smooth gate entry and the expansion areas (7) allows the seat to be axially flexible requiring minimal operating force.

Design data

Sizes	Flange drilling	Face-to-face dimension	Corrosion protection
DN 80 - DN 450	EN 1092 PN20 EN 1092 PN25 EN 1092 PN40 EN 1092 PN50 ASME/ANSI B16.5 Class 150 ASME/ANSI B16.5 Class 300 AS 2129 Table F/H	Stafsjö manufacturing standard	Non-corrosive resistant materials are coated in colour RAL5015 acc. to Stafsjö's standard, which fulfill the requirements in EN ISO 12944 class C3.

Other sizes, flange drillings, ATEX zones and corrosion protection on request.

Leakage rate	Pressure tests
EN 12266-1:2009 Rate A: no visually detectable leakage is allowed for duration of the test.	Pressure tests are performed with water at 20° C according to EN 12266-1:2009. Pressure shell test: 1,5 times maximum allowable working pressure for open valve. Pressure seat tightness test: 1,1 times maximum allowable differential pressure for closed valve.

Maximum working pressure body at 20°C		Maximum differential pressure at 20°C	
Valve type and sizes	bar	Valve type and sizes	bar
SLH DN 80 - DN 450	20	SLH DN 80 - DN 450	20
SLX DN 80 - DN 450	50	SLX DN 80 - DN 450	50

Basic equipment

A. Valve Body			
Material	Code	Type	Maximum temperature °C
Nodular iron	(L)	5.3105 (JS1020)	200

The valve body is as standard supplied with purge ports: DN 80-DN 150: 3/4" - 1/2", DN 200: 3/4", DN 250: 3/4" - 1", DN 300: 1", DN 350 1" - 1 1/4", DN 400 - DN 450: 1 1/4"

B. Gate			
Valve type	Material	Type	Surface treatment
SLH	Duplex stainless steel	EN 1.4462 (S32205)	Hard anti-stick coated
SLX	Stainless steel	EN 1.4542 (S17400/17-4PH)	Hard anti-stick coated

Other materials on request

C. Seats		
Material	Code	Maximum temperature °C
Natural rubber	(NR)	80
EPDM	(E)	120

D. Box packing		
Material	Code	Maximum temperature °C
TwinPack™ with scrapers in UHMWPE	(TY)	80

Actuators

Manual	Code	Automatic	Code
Hand wheel	(HWR)	Electrical motor	(EM)
Bevel gear	(BG)	Hydraulic cylinder	(MH)
		Double-acting pneumatic cylinder	(EC)

The actuators are described in separate data sheets. For information on the sizing for each valve size or information on other actuators or ATEX-classified ones, please contact Stafsjö or your local representative.

Specify the Stafsjö valve

Stafsjö's valves are modular designed and they can easily be customized with gate, seat materials and box packings according to media and requirements, as well for actuators and accessories. Below are examples of how you can specify your Stafsjö valve. Further information is available on www.stafsjo.com.

SLH-L-200-E-TY-HWR-PN25

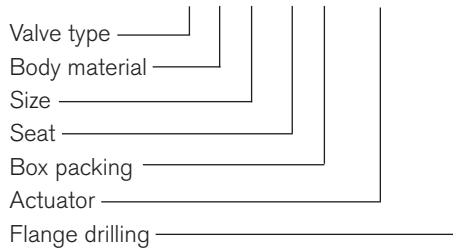

¹⁾ All electronics must be specified in detail.

SLH-L-200-E-TY-EC250-ANSI300-ILS-SV

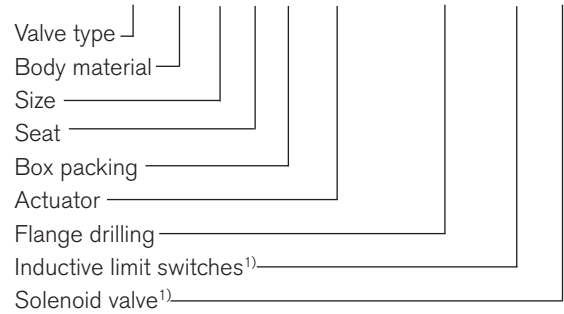

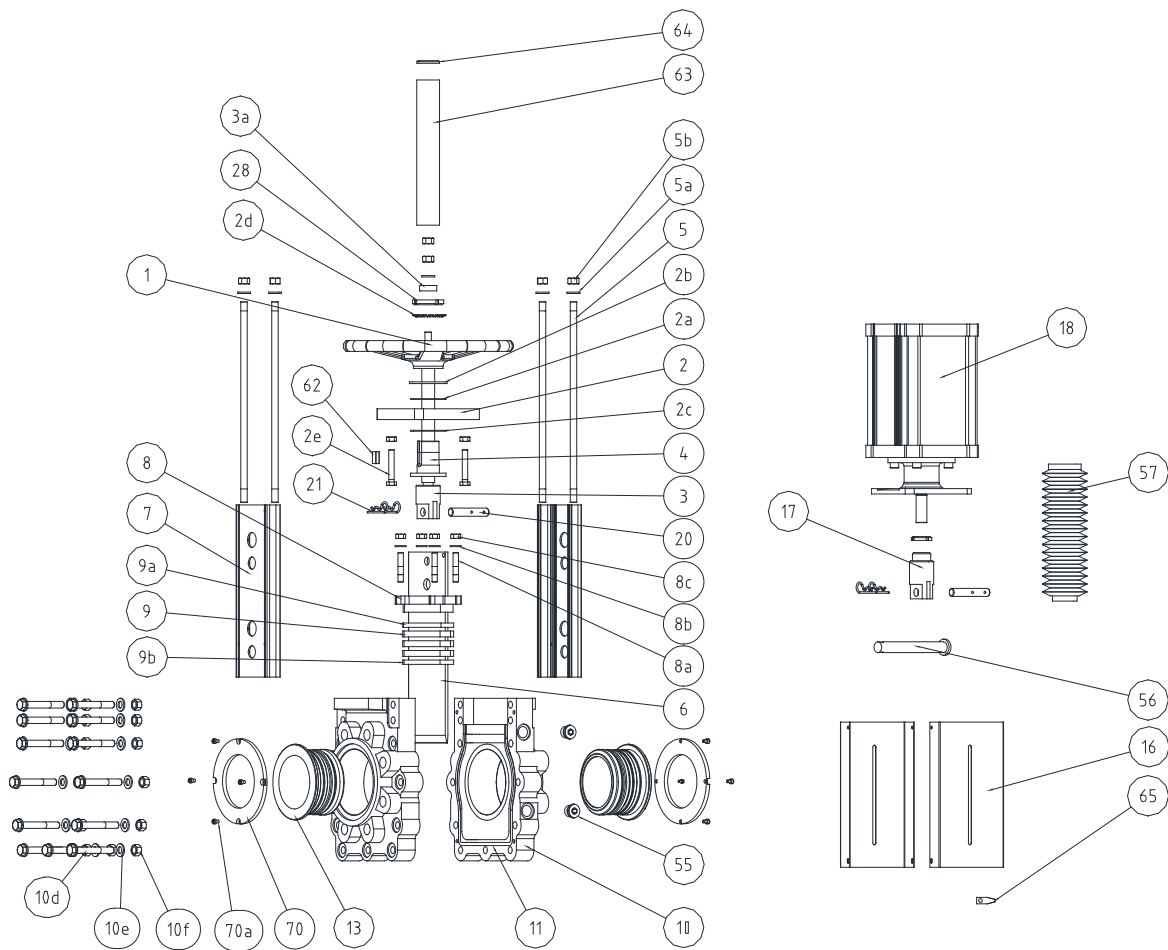

Part list

Pos.	Part	Material (Name)
1	Hand wheel	Coated cast iron Ø 200 - Ø 315 (EN-JL1040 (GG25)), ≥ Ø 400 (EN-JL1030 (GG20))
2	Yoke	Coated steel (EN 1.0038)
2a	Bearing	Iglidur XTM
2b	Slide washer	Brass (CW614N)
2c	Bearing	Iglidur XTM
2d	Washer	Stainless steel (EN 1.4305)
2e	Locking nut	Steel, zinc coated
3	Stem with gate clevis	Stainless steel (EN 1.4305) ≥ DN 300: Gate clevis in coated carbon steel (EN 1.0045)
3a	Stop washer	Stainless steel (EN 1.4301)
3b	Screw	Stainless steel (A2)
3c	Washer	Stainless steel (A2)
4	Stem nut	Brass (CW614N)
5	Tie rod	≤ DN 250: Stainless steel (EN 1.4301)
5a	Washer	Stainless steel (A2)
5b	Nut	Stainless steel (A2)
6	Gate	See equipment B
7	Beam	≤ DN 250: Aluminium (EN AW-6063-T6) ≥ DN 300: Coated steel (EN 1.0038)
8	Gland	Coated nodular iron (EN-JS1050 (GGG50))
8a	Stud bolt	Stainless steel (A2), zinc coated
8b	Washer	Stainless steel (A2), zinc coated
8c	Nut	Stainless steel (A2), zinc coated
9 ³⁾	Box packing	See equipment D

Pos.	Part	Material (Name)
9a ³⁾	Box bottom scraper	See equipment D
9b ³⁾	Scraper with o-ring	See equipment D
10/a/b	Valve body	See equipment A
10d	Screw	Steel, zinc coated
10e	Washer	Steel, zinc coated
10f	Nut	Steel, zinc coated
11	Body gasket	PTFE
13 ³⁾	Seat	See equipment C
16	Gate guard, not for HW	Stainless steel (EN 1.4301)
17	Gate clevis	Stainless steel (EN 1.4305) ≥ DN 350: Coated carbon steel (EN 1.0045)
18	Cylinder	See data sheet
20	Clevis pin	Stainless steel (EN 1.4305)
21	Split pin	Stainless steel (EN 1.4436)
55	Plug	Steel, zinc coated
56 ²⁾	Locking pin	See data sheet for Stafsjö's accessories
57 ²⁾	Stem protection	See data sheet for Stafsjö's accessories
62	Wedge	Stainless steel
63	Stemtube	Coated stainless steel (EN 1.0038)
64	Plug	Plastic
65	Gate indicator	Stainless steel (EN 1.4301)
70 ²⁾	Load distribution rings	See data sheet for Stafsjö's accessories
70a ²⁾	Screws	See data sheet for Stafsjö's accessories

²⁾ Optional accessories

³⁾ Recommended spare parts

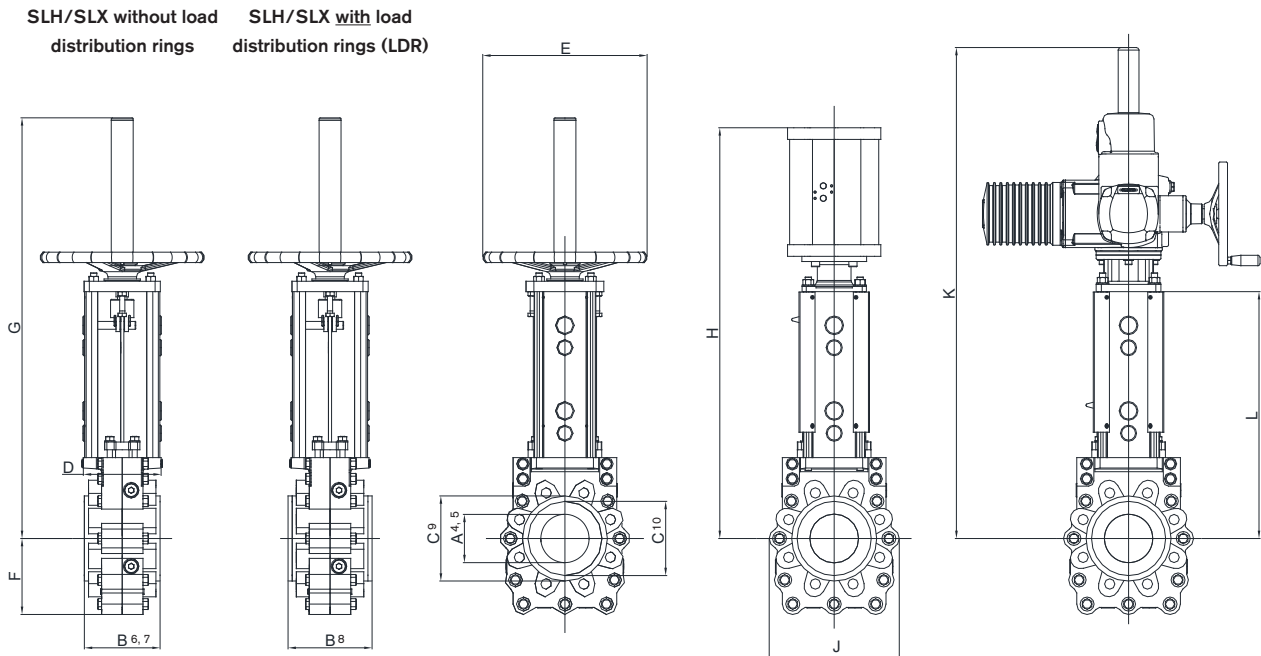

Main dimensions for SLH/SLX

Dimensions (mm)																	
DN	A ⁴⁾	A ⁵⁾	B ⁶⁾	B ⁷⁾	B ⁸⁾	C ⁹⁾	C ¹⁰⁾	D	E	F	G	H	J	K	L	Weight ¹¹⁾	Weight ¹²⁾
80	80	75	151	146	158	130	-	150	315	123	614	730	210	590	420	39	41
100	100	93	151	146	162	164	-	150	400	147	812	858	251	660	476	46	64
150	148	145	154	149	165	216	-	150	520	191	900	1004	323	820	565	87	110
200	199	190	161	156	172	271	-	175	520	237	1133	1177	412	990	683	130	152
250	249	240	226	221	241	331	-	175	630	267	1215	1316	467	1170	765	192	222
300	293	283	248	242	262	400	-	210	-	303	-	1497	537	1350	859	-	324
350	337	327	257	251	271	442	-	210	-	239	-	1641	571	1490	961	-	426
400	375	365	280	273	293	-	465	310	-	374	-	1824	675	1630	1094	-	568
450	431	400	310	302	322	-	516	310	-	426	-	2098	761	2080	1192	-	748

A⁴⁾ Inlet diameter. A⁵⁾ Bore diameter.

B⁶⁾ Minimum required face-to-face for installation without load distribution rings. B⁷⁾ Installed face-to-face without load distribution rings.

B⁸⁾ Installed face-to-face with load distribution rings (LDR). When the connecting flanges are rubber lined or when they do not cover the metal frame around the seats, dimension C⁹⁾ on \leq DN 350 or dimension C¹⁰⁾ + 20 mm for \geq DN 400, there is a need to install load distribution rings between the seats and the flanges to avoid functional problems and to ensure the seats will stay in correct position after every valve manoeuvring. If load distribution rings are ordered they are as standard assembled on the valve upon delivery.

¹¹⁾Weight in kg for valve including hand wheel.

¹²⁾Weight in kg for valve including double-acting pneumatic cylinder type EC.

Main dimensions are only for information. Contact Stafsjö for certified drawings.

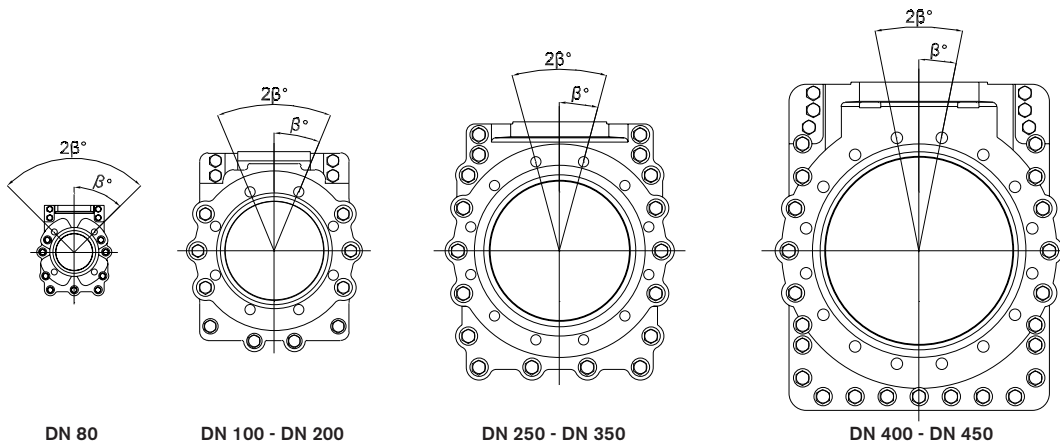

Flange drilling according to EN 1092 PN 20

Flange drilling information (mm)									
DN	80	100	150	200	250	300	350	400	450
Outside flange diameter	190	230	280	345	405	485	535	600	635
Bolt circle diameter	152,5	190,5	241,5	298,5	362	432	476	540	578
Number of tapped holes (◦)	4	8	8	8	12	12	12	16	16
Bolt size	M16	M16	M20	M20	M24	M24	M27	M27	M30
β°	45	22,5	22,5	22,5	15	15	15	11,25	11,25
Depth of tapped holes ¹³⁾	33	33	34	29	57	61	65	45	45

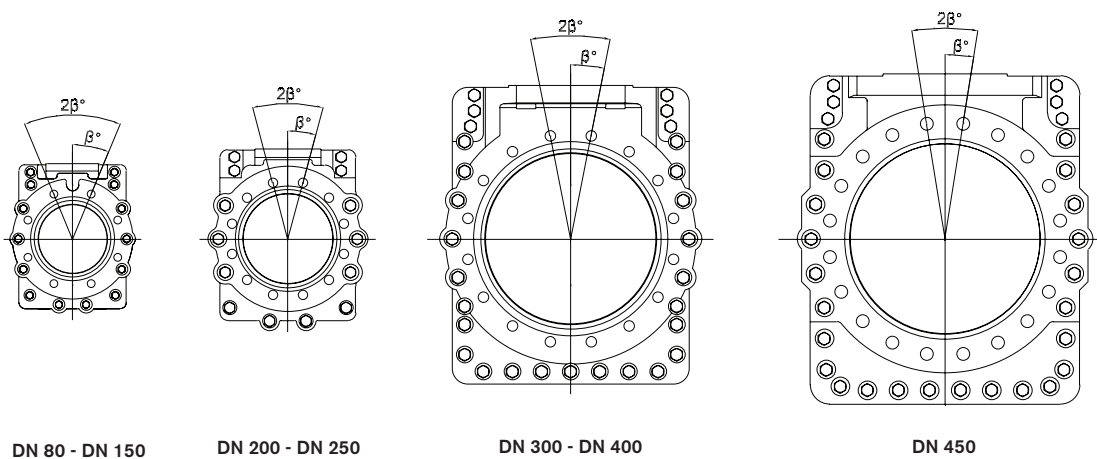

Flange drilling according to EN 1092 PN 25

Flange drilling information (mm)									
DN	80	100	150	200	250	300	350	400	450
Outside flange diameter	200	235	300	360	425	485	555	620	670
Bolt circle diameter	160	190	250	310	370	430	490	550	600
Number of tapped holes (◦)	8	8	8	12	12	16	16	16	20
Bolt size	M16	M20	M24	M1624	M27	M27	M30	M33	M33
β°	22,5	22,5	22,5	15	15	11,25	11,25	11,25	9
Depth of tapped holes ¹³⁾	33	33	34	29	57	61	65	45	45

¹³⁾ Add the values with the thickness of flanges and washers.

◦ Tapped holes

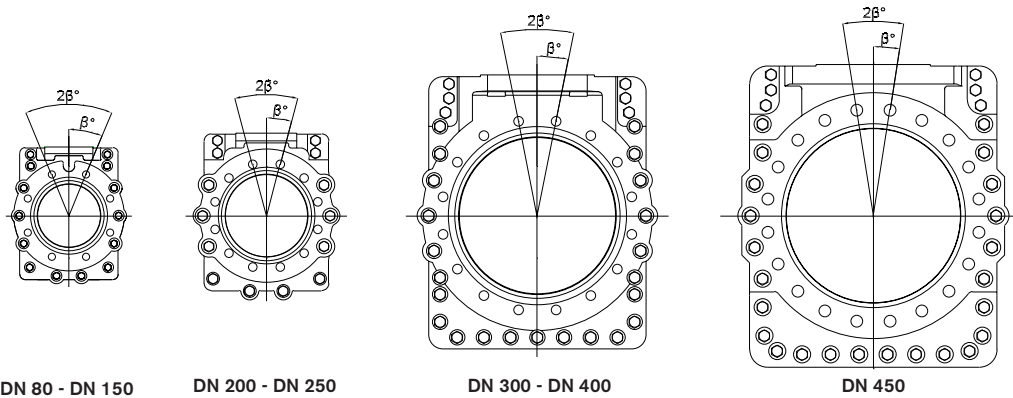

Flange drilling according to EN 1092 PN 40

Flange drilling information (mm)									
DN	80	100	150	200	250	300	350	400	450
Outside flange diameter	200	235	300	375	450	515	580	660	685
Bolt circle diameter	160	190	250	320	385	450	510	585	610
Number of tapped holes (°)	8	8	8	12	12	16	16	16	20
Bolt size	M16	M20	M24	M27	M30	M30	M33	M36	M36
β°	22,5	22,5	22,5	15	15	11,25	11,25	11,25	9
Depth of tapped holes ¹³⁾	33	33	34	29	57	61	65	45	45

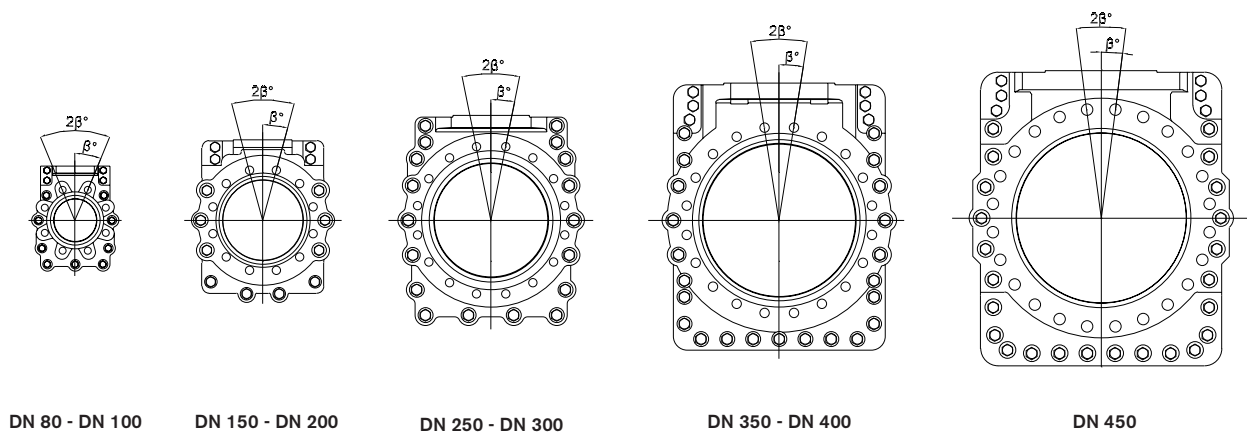

Flange drilling according to EN 1092 PN 50

Flange drilling information (mm)									
DN	80	100	150	200	250	300	350	400	450
Outside flange diameter	210	255	320	380	445	520	585	650	710
Bolt circle diameter	168,5	200	270	330	387,5	451	514,5	571,5	629
Number of tapped holes (°)	8	8	12	12	16	16	20	20	24
Bolt size	M20	M20	M20	M24	M27	M30	M30	M33	M33
β°	22,5	22,5	15	15	11,25	11,25	9	9	7,5
Depth of tapped holes ¹³⁾	33	33	34	29	57	61	65	45	45

¹³⁾ Add the values with the thickness of flanges and washers.

° Tapped holes

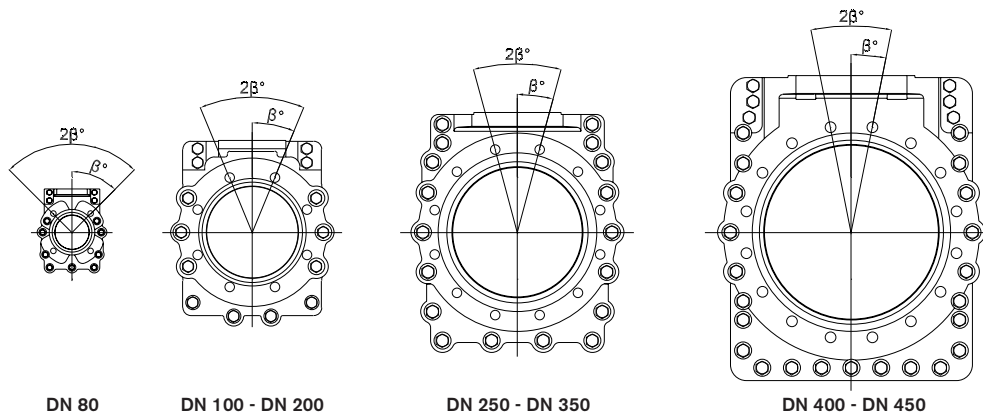

DN 80

DN 100 - DN 200

DN 250 - DN 350

DN 400 - DN 450

Flange drilling according to ASME/ANSI B16.5 Class 150

Flange drilling information (mm)									
DN	80	100	150	200	250	300	350	400	450
Outside flange diameter	190,5	228,6	279,4	342,9	406,4	482,6	533,4	596,9	635
Bolt circle diameter	152,4	190,5	241,3	298,5	362	431,8	476,3	539,8	577,9
Number of tapped holes (◦)	4	8	8	8	12	12	12	16	16
Bolt size (UNC)	5/8"-11	5/8"-11	3/4"-10	3/4"-10	7/8"-9	7/8"-9	1"-8	1"-8	1 1/8"-7
β°	45	22,5	22,5	22,5	15	15	15	11,25	11,25
Depth of tapped holes ¹³⁾	33	33	34	29	57	61	65	45	45

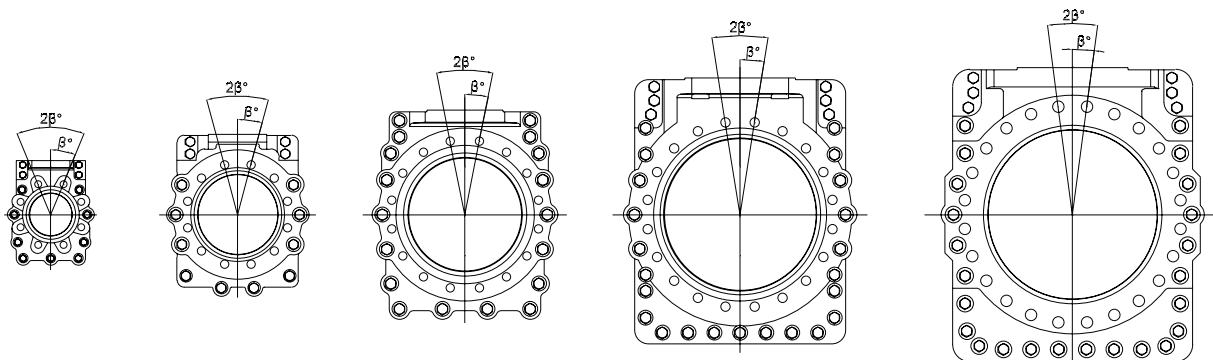

DN 80 - DN 100

DN 150 - DN 200

DN 250 - DN 300

DN 350 - DN 400

DN 450

Flange drilling according to ASME/ANSI B16.5 Class 300

Flange drilling information (mm)									
DN	80	100	150	200	250	300	350	400	450
Outside flange diameter	209,6	254	317,5	381	444,5	520,7	584,2	647,7	711,2
Bolt circle diameter	168,1	200,2	269,7	330,2	387,4	450,9	514,4	571,5	628,7
Number of tapped holes (◦)	8	8	12	12	16	16	20	20	24
Bolt size (UNC)	3/4"-10	3/4"-10	3/4"-10	7/8"-9	1"-8	1 1/8"-7	1 1/8"-7	1 1/4"-7	1 1/4"-7
β°	22,5	22,5	15	15	11,25	11,25	9	9	7,5
Depth of tapped holes ¹³⁾	33	33	34	29	57	61	65	45	45

¹³⁾ Add the values with the thickness of flanges and washers.

◦ Tapped holes

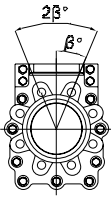

DN 80 - DN 100

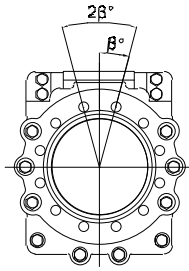

DN 150 - DN 250

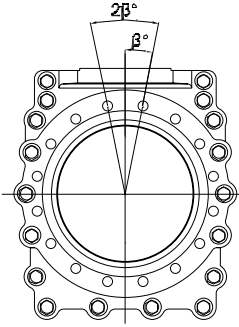

DN 300 - DN 350

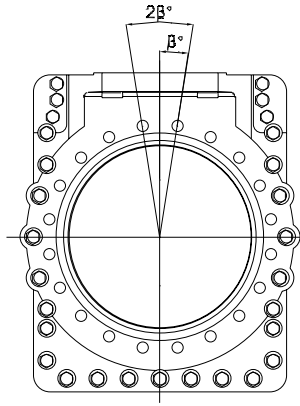

DN 450

Flange drilling according to AS Table F

Flange drilling information (mm)									
DN	80	100	150	200	250	300	350	400	450
Outside flange diameter	205	230	305	370	430	490	550	610	675
Bolt circle diameter	165	191	260	324	381	438	495	552	610
Number of tapped holes (°)	8	8	12	12	12	16	16	20	20
Bolt size	M16	M16	M20	M20	M24	M24	M27	M27	M30
β°	22,5	22,5	15	15	15	11,25	11,25	9	9
Depth of tapped holes ¹³⁾	33	33	34	29	57	61	65	45	45

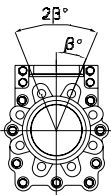

DN 80 - DN 100

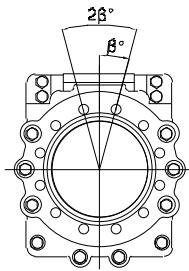

DN 150 - DN 250

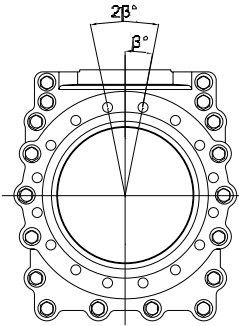

DN 300 - DN 350

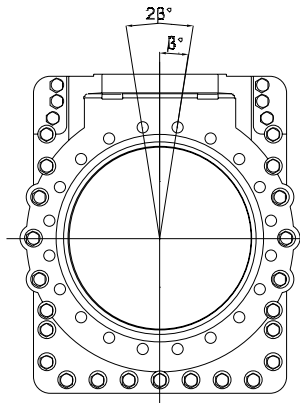

DN 450

Flange drilling according to AS Table H

Flange drilling information (mm)									
DN	80	100	150	200	250	300	350	400	450
Outside flange diameter	205	230	305	370	430	490	550	610	675
Bolt circle diameter	165	191	260	324	381	438	495	552	610
Number of tapped holes (°)	8	8	12	12	12	16	16	20	20
Bolt size	M16	M16	M20	M20	M24	M24	M27	M27	M30
β°	22,5	22,5	15	15	15	11,25	11,25	9	9
Depth of tapped holes ¹³⁾	33	33	34	29	57	61	65	45	45

¹³⁾ Add the values with the thickness of flanges and washers.

° Tapped holes

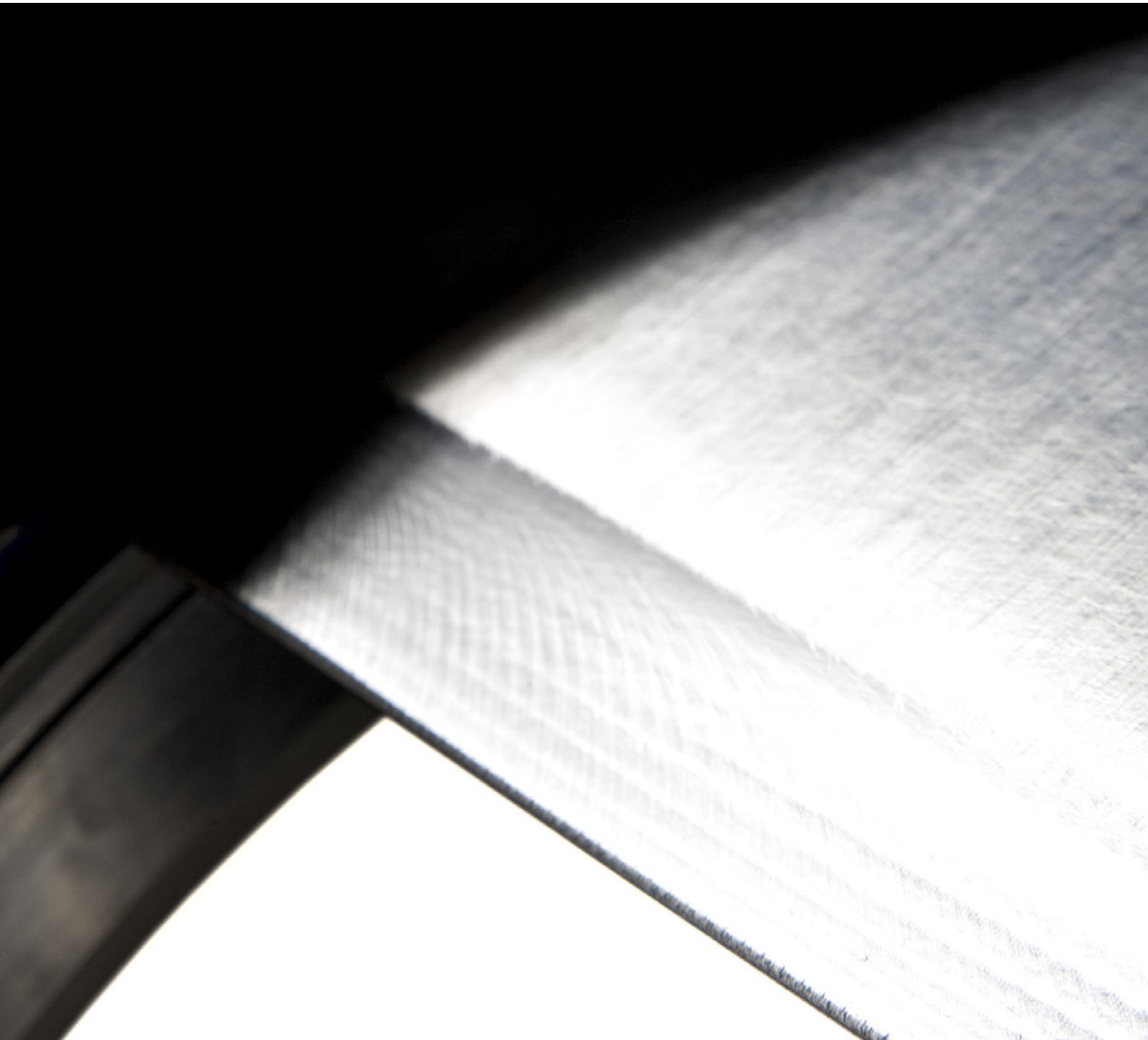

Globally active. Locally represented.

AFRICA South Africa: Valve & Automation (Pty) Ltd, **ASIA** China: Ebro Armaturen (Beijing) co., Ltd, India: Ebro Armaturen India Pvt. Ltd, Indonesia: Contromatic Prima Mandiri PT, Japan: SKC Co. Ltd, Malaysia: Precision Control SdnBnd, Philippines: Ebro Armaturen (Philippines) Inc., South Korea: Sherpa Automation, Thailand: Ebro Valves (Trading) Co. Ltd., Vietnam: Ebro Valves (Thailand) Co., Ltd, **AUSTRALIA with OCEANIA** Australia: Ebro Armaturen Pacific Pty Ltd, New Zealand: H.J. Asmuss & Co. Ltd **EUROPE** Austria: Ebro Armaturen GmbH, Belgium: V.C.T. - Valve & Connector Technology n.v., Denmark: Valtor Industri A/S, Finland: Tecalemit Flow Oy, France: Ebro Armaturen, Germany: Ebro Armaturen Gebr. Bröer GmbH, Great Britain: Ebro Valves Ltd, Hungary: Ebro Armaturen Kft, Ireland: ESI Technologies Ltd., Iceland: Hédinn HF, Italy: Ebro Valvole srl, The Netherlands: Ebro Valves B.V., Norway: Bagges AS, Poland: Ebro Armaturen GmbH, Portugal: AxFlow Comércio de Equipamentos Lda, Russia: LesBumMash Ltd, Roitech and OOO Hawle Sevkom, Spain: Ebro Armaturen España, S.L., Switzerland: Ebro Armaturen Est. & Co. KG, Sweden: Stafsjö Valves AB and Ahlsell Sverige AB, Turkey: Ebro Armaturen Otomasyon Sistemleri San ve Tic Ltd. Şti, Ukraine: Ebro Armaturen GmbH Representative office Kiev **NORTH AMERICA** Canada: Armour Valve Ltd, USA: Ebro Armaturen USA Inc. **SOUTH AMERICA** Argentina: Esco Argentina S.A., Bolivia: Sutein, Brazil: ELAN Equipamentos Industriais Ltda, Chile: Ebro Stafsjö Valves Chile Ltd, Peru: Ebro Armaturen Perú, For other countries, please contact us directly.

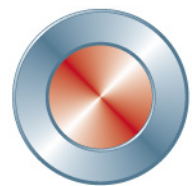

Stafsjö
SINCE 1666

avrora-arm.ru
+7 (495) 956-62-18